

SHELTER ASSEMBLY MANUAL

26x20x10 Container Shelter Single truss



PARTS LIST

Part Code	Description	Qty
L1	Base plate with tie down ratchet on left side	4
R1	Base plate with tie down ratchet on right side	4
1	Top bent tube	4
2	Middle bent tube	8
3	Sidewall bent tube	8
4	Connection purlin	15
5	Support tube	12
6	Clip	24
7	Lower tensioning tube for roof cover	2 Groups
8	Roof cover	1
9	Bolt M8x70	60
10	Bolt M10x80	25
11	Ropes	1 dozen
12	φ 32 Plastic plug for base rail section	4
13	Ratchet strap (To tie down ratchet)	10
14	Ratchet	8
15	Angle seat	4

ANCHORING THE CONTAINER

Make sure you have:

- Welder.
 - Cement.
 - Four 3" x 3" x 6 feet 1/4" Square steel angle
1. As shown in the diagram 1, make a 3 ft deep hole right beside one of the front and opposite rear corners of the container, in which the 6ft square steel will be installed.
 2. Insert the 6ft square steel into the hole, making sure 3ft is below the surface completely laying on the side of the containers.
 3. Weld the square steel to the 2 containers.
 4. Pour cement in the holes to make sure the square steel won't move.
 5. Repeat the previous steps on the corners located in the opposite rear side.

Securing the containers to the floor is crucial, that way the containers won't shift under harsh weather conditions, thus avoiding the shipping container canopy roof top of getting damaged.

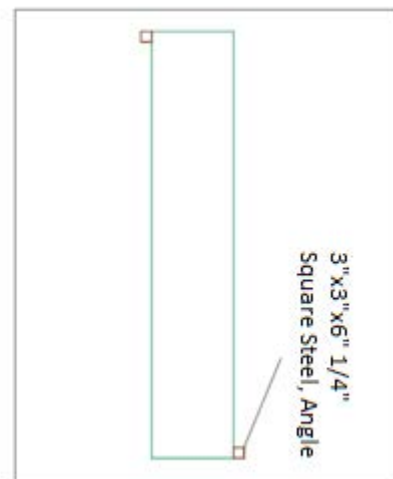
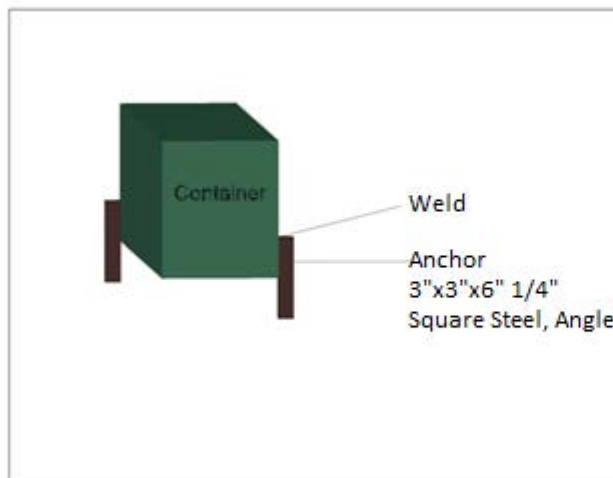

Highly Recommended

1. All container canopy covers need to be removed during windstorm of 60 mph, leaving frame assembled. **Customer responsibility.**
2. All container canopy covers need to be removed before a snowstorm of 1-2 inches (for single truss Shipping container roofs) and 3-4 inches (for double truss Shipping container roofs), leaving the frame assembled. **Customer responsibility.**
3. It is highly recommended for customers who live in snow states and cities to use double truss framing instead of Single truss framing. **Customer responsibility.**
4. It's the owner's responsibility to shovel snow off the canopy rooftop.
5. All containers need to be anchored to the ground in each opposite corner sides. **Customer responsibility.**
6. All of our products fall under the temporary structure category/storage ragtops.

Return Policy: Any product can be returned within 7 calendar days after arrival; shipping expenses are not refundable. For more information, please refer to the **Return and refund policy** page.

About lifespan:

Tarp lifespan: 7-10 years*

Frame Lifespan: +15 years*

****The term "lifespan" refers to the durability of the materials themselves, not to the structural integrity of the canopy once assembled.***



SPECIFICATIONS

Width: 26 ft Length: 20 ft Height: 10 ft

IMPORTANT: READ MANUAL FIRST

Improper site preparation, assembly and maintenance may invalidate warranty and cause unnecessary and costly mistakes. If you have any questions, contact your local dealer.

For an easy assembly process, we have identified each individual component with the part code as indicated in the parts list. Please refer to the part code numbers and drawing to ensure problem-free assembly.

It is necessary to tighten the roof fabric enough to avoid “hammocks” on the roof; also re-tighten once or twice again after a few months of use. This is important when assembled during cold seasons (autumn and winter) because the fabric gets stiff in these weather conditions. When the weather conditions become warmer, the fabric loosens and needs to be re-tighten

It is the owner’s responsibility to take off snow immediately, otherwise it will slide off on its own.

READ ALL INSTRUCTIONS BEFORE ASSEMBLY

1. Keep the work area clean. Accidents are more likely in cluttered areas. Do not set up near snow drifts, in slippery places, in high winds, or wet locations.
2. All children should be kept away from the work area.
3. Don’t overreach. Always keep proper footing and balance.
4. Do not assemble under the influence of alcohol or drugs. Read warning labels on medication prescriptions to determine if your judgment or reflexes are impaired while taking them. If there is any doubt, do not assemble.
5. Be aware of possible windy conditions; fasten the bases in concrete if these conditions are likely to occur. Remove the cover during hurricanes.
6. Be careful with power and heat sources. Do not keep heat sources near the tarpaulin. Do not expose to open flame.
7. Be aware of personal safety during assembly and use. Be careful not to pinch your fingers with clips and tubes when assembling: When using, make sure there is adequate ventilation for any dangerous fumes.

EQUIPMENT AND TOOLS FOR INSTALLATION

1. Measuring tape
2. Alignment string
3. Step ladder
4. Welder
5. Sledgehammer
6. Wrench
7. Scissors

INSTALLATION PROCESS

A - BASE PLATES INSTALLATION

Please refer to the Figure 1 to place the base plates.

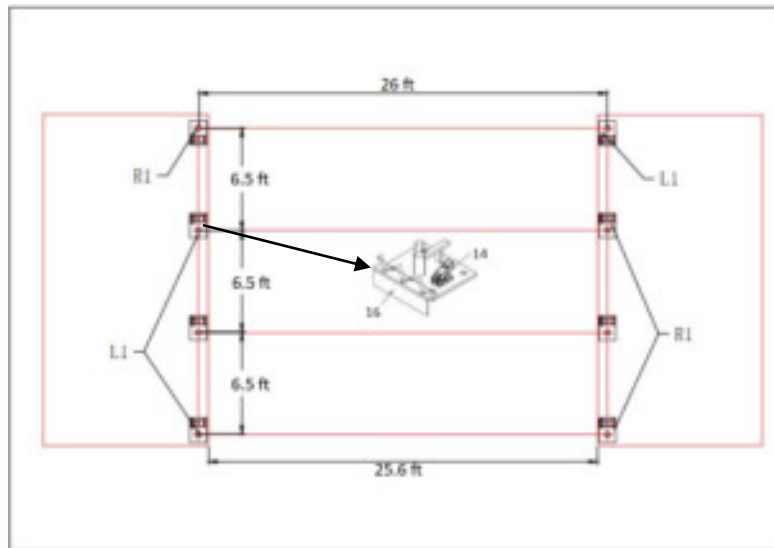

Figure 1

1. The measure must be taken from center to center of the base plates. Refer to the diagram above and confirm the place of the base plates. ENSURE THAT THE FOUNDATIONS ARE SQUARE.
2. All the base plates need to be welded on the Containers.

B - FRAME INSTALLATION (Refer to figure 2 for the full diagram)

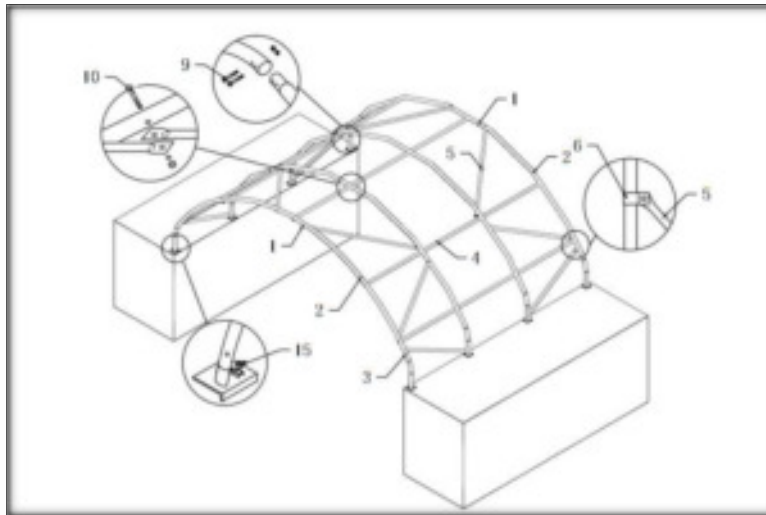

Figure 2

1. As shown in figure 3, connect the Top bent tube (part code 1), the Middle bent tube (part code 2) and the Sidewall bent tube (part code 3) with the Bolts M8x70 (part code 9); these make one group of arches. Please NOTE the direction of the bolt. **DO NOT** install the bolts on the top of the truss where the fabric will rest.
2. Insert one end of the assembled arch into one base plate and insert the other end of the arch into the opposite base plate. Secure the arches on the base plates using the bolts.

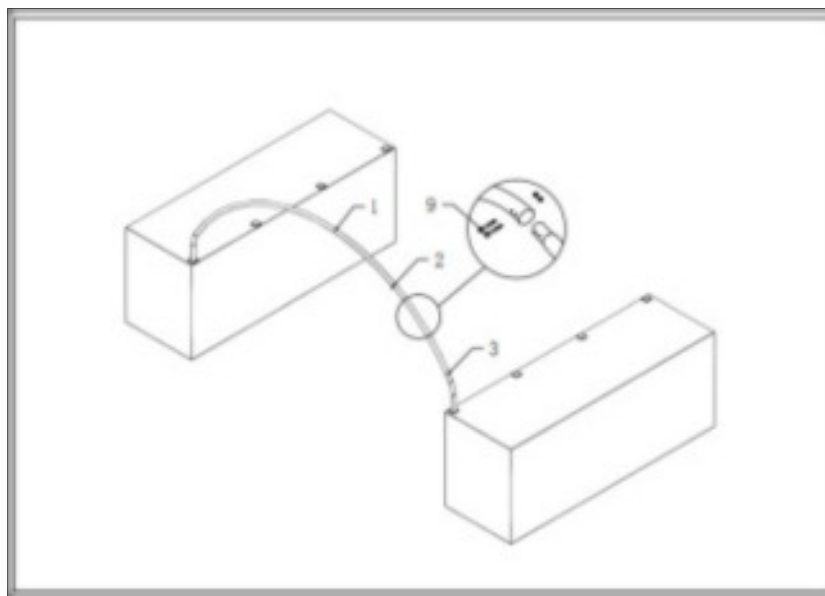

Figure 3

3. After installing the first two arches, connect the Connection purlin (part code 4) onto them using the Bolt M10x80 (part code 10). There are 5 pieces of Connection purlins (part code 4) between each arch. (Refer to figure 4)
4. Install Support tube (part code 5) using the Clip (part code 6).

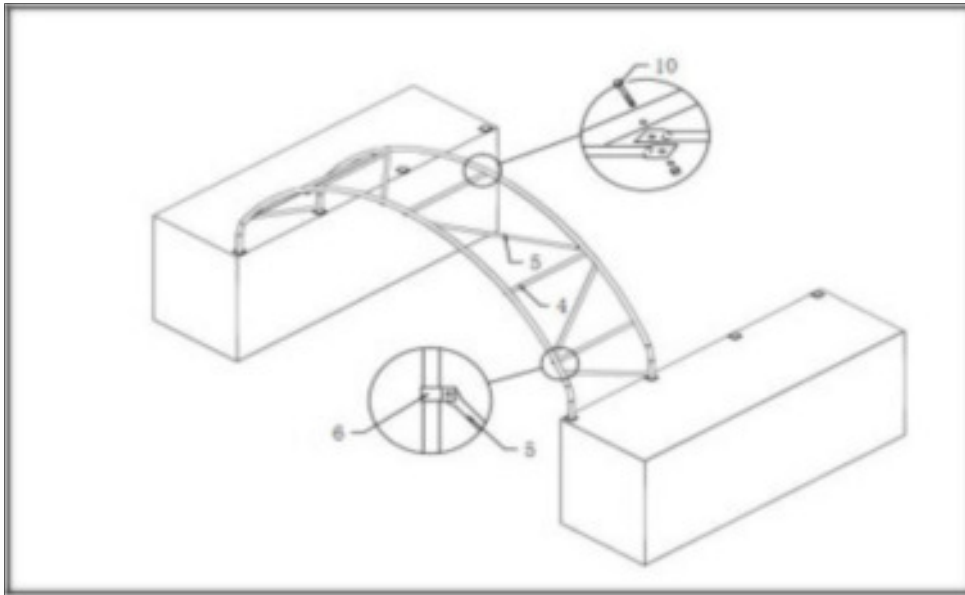

Figure 4

5. Then install the third arch into the base plate and connect the purlins.
6. Assemble the arches one by one until the frame is finished.

C - ROOF COVER INSTALLATION

NOTE: DO NOT install the cover onto the frame of your building in high wind conditions. A slight breeze is the most advantageous for cover installation. To take advantage of the breeze, pull the cover up over the arches with the breeze blowing in the cover like a sail filled with air.

1. Insert the Lower tensioning tube for roof cover (part code 7) into the pockets on the end of the roof cover (part code 8). Then put the ϕ32 Plastic plug for base rail section (part code 12). (Refer to figure 5)

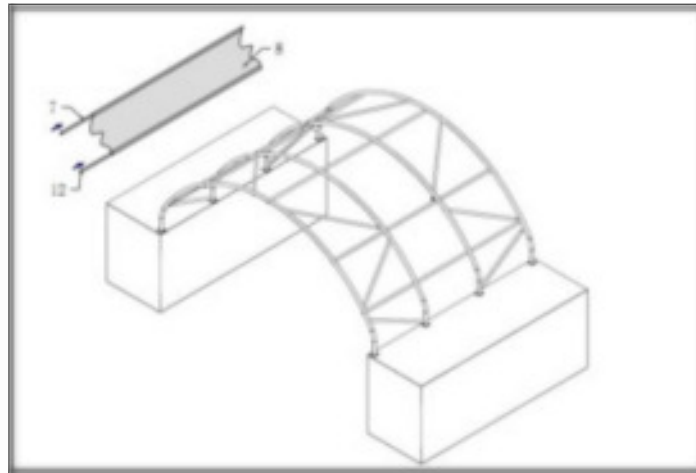

Figure 5

2. Put the Roof cover (part code 8) EVENLY, CAREFULLY AND SLOWLY atop the frame. Adjust the cover so that it is square and evenly centered on the frame. Refer to figure 6)

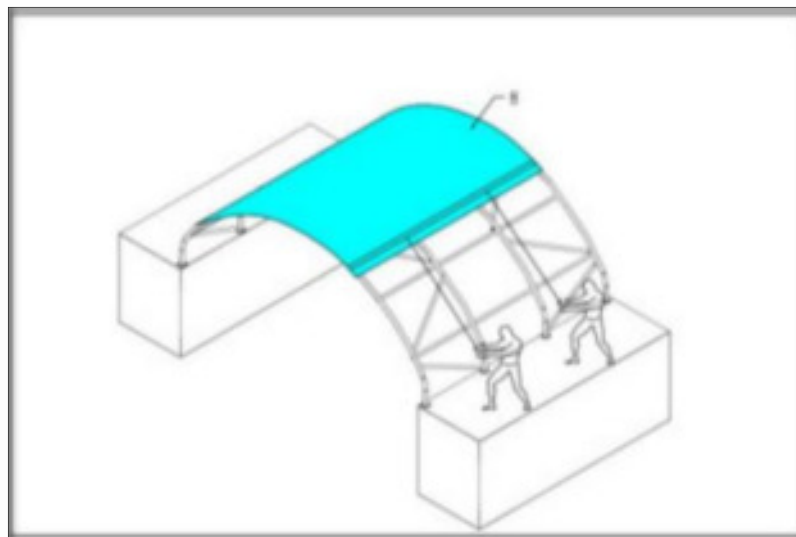

Figure 6

- On the Roof cover, cut pockets over each ratchet on the base plates, then use the Ratchet strap (part code 13) to tie down the Lower tensioning tubes. (Refer to figure 7)

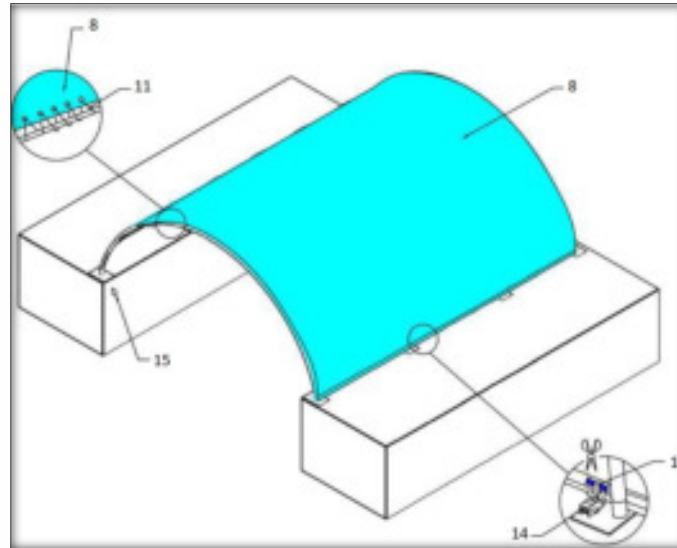

Figure 7

- Weld the Angle seats (part code 15) on each container and use the Rope (part code 11) to knit the cover on the two external arches. Then tie the Rope to the Angle seats (Refer to figure 8).

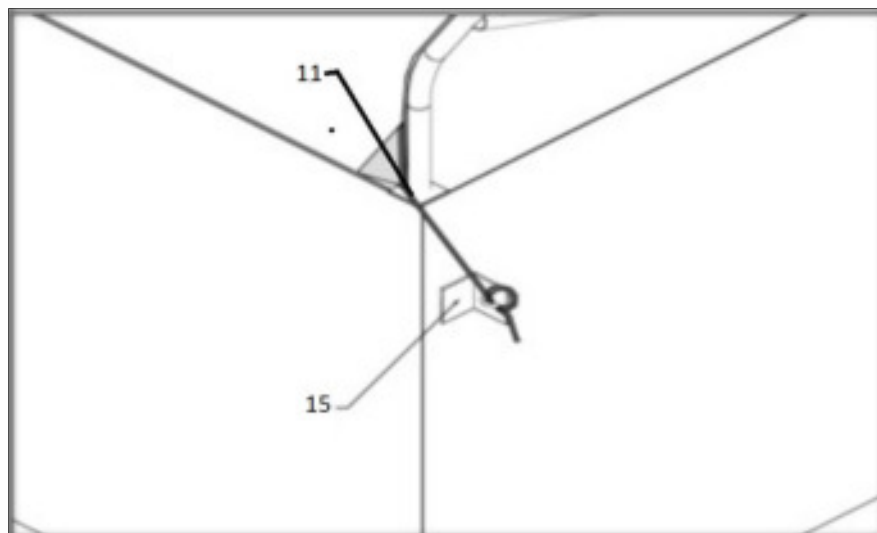

Figure 7

Please, check our installation images and videos section by clicking the following link:
https://drive.google.com/drive/u/3/folders/1p9FLejo-JlrkJPx5_Kp-hDcssOph2dWa



NOTES:

- DO NOT LEAVE THE ROOF COVER UNATTACHED UNDER ANYCIRCUMSTANCES until the final assembly and tightening has been completed.
- The process is quite easy, but some tightening adjustments will be necessary to get a flat, tensioned roof cover. Please adjust the roof cover every month.
- Wrap tape around the gap between the steel after installing.

